



Iridium Antenna

Installation Guide

BLUE SKY NETWORK, LLC
5353 Mission Center Rd. #222
San Diego, CA 92108, USA

Iridium Antenna

Installation Guide

Version 3.0

Part Number: CI 490-501

NOTICE

This guide is published and copyrighted by Blue Sky Network (BSN). All information and specifications in this document are subject to change without notice. Nothing in this document is intended to create additional or separate warranties or guarantees.



Blue Sky Network, 5353 Mission Center Rd. #222, San Diego, CA 92108

Phone: +1 858-551-3894 | Fax: +1 858-225-0794

Email: support@blueskynetwork.com | Website: www.blueskynetwork.com

© 2022 Blue Sky Network, All Rights Reserved

TABLE OF CONTENTS

NOTICE	3
INTRODUCTION	7
OVERVIEW	7
SYSTEM DESCRIPTION & OPERATION	8
System Description	8
Iridium Satellite Network	9
FAA/JAA APPROVAL	10
Installation & Operational Approval Procedures	10
Instructions for Continued Airworthiness	10
Environmental Qualification	10
<i>SINGLE-CHANNEL ANTENNA</i>	10
<i>DUAL-CHANNEL ANTENNA</i>	10
<i>GNSS & IRIDIUM ANTENNA</i>	10
EQUIPMENT SPECIFICATIONS & DRAWINGS	11
Single-Channel Antenna	11
Dual-Channel Antenna	12
GNSS & Iridium Antenna	13
INSTALLATION & WIRING	15
License Requirements	15
Equipment Required, But Not Supplied	15
Antenna & Antenna Cable Installation	15
<i>SINGLE-CHANNEL ANTENNA (S67-1575-109) INSTALLATION</i>	15
<i>DUAL-CHANNEL ANTENNA (CI 490-501) INSTALLATION</i>	16
<i>GNSS & IRIDIUM ANTENNA (S5GIRG3RR-AP-XTS-1) INSTALLATION</i>	16
<i>ANTENNA CABLE INSTALLATION</i>	17
<i>ANTENNA CABLE ROUTING CONSIDERATIONS</i>	17
POST-INSTALLATION PROCEDURES	18

Ground Test & Operational Flight Check Procedure18

Maintenance18

AIRCRAFT ANNUAL INSPECTION CONSIDERATIONS.....18

TECHNICAL SUPPORT **19**

PAGE INTENTIONALLY LEFT BLANK

INTRODUCTION

This guide is applicable to the following components.

Part Number	Component Description
S67-1575-109	Iridium-tuned single-channel antenna
CI 490-501	Iridium-tuned dual-channel antenna
S5GIRG3RR-AP-XTS-1	GNSS & Iridium antenna
Notes	

OVERVIEW

The information in this guide describes the features, functions, technical characteristics, components, approval procedures, installation considerations, setup & checkout procedures, and instructions for continued airworthiness for an Iridium antenna installation.

The information, drawings, and wiring diagrams in this guide are intended as a reference for engineering planning only and do not represent any specific STC, Form 337, or Form 1 aircraft installation. It is the installer's responsibility to create installation drawings specific to the aircraft. This guide and the drawings and wiring diagrams contained herein may not be used as a substitute for any drawing package.

SYSTEM DESCRIPTION & OPERATION

System Description

The Iridium-tuned antenna is an L-band antenna tuned to the Iridium system frequency of 1616 MHz to 1626.5 MHz. The antenna is TSO'd and qualified for high-speed military and commercial aircraft.

Individual component descriptions and specifications are detailed in the **Equipment Specifications and Drawing** section of this document.



Single-Channel Antenna



GNSS & Iridium Antenna



Dual-Channel Antenna

Iridium Satellite Network

The Iridium satellite system provides truly mobile satellite voice and data solutions with complete coverage of the Earth (including oceans, airways, and polar regions). Through a constellation of 66 low-earth orbiting (LEO) satellites, Iridium delivers essential communications services to and from remote areas where terrestrial communications are not available.

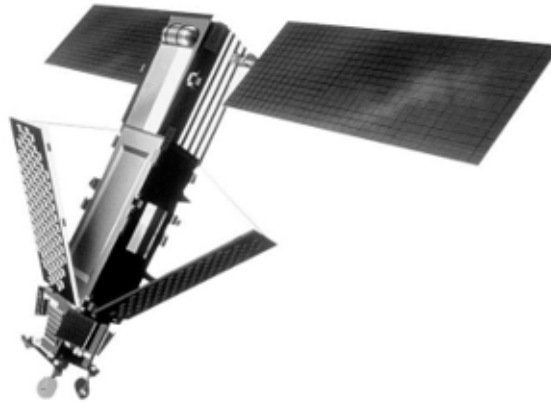

Satellites	66 (plus 6 in-orbit backup satellites)
Orbital Planes	6
Orbit Altitude	485 miles (780 kilometers)
Inclination of Orbital Plane	86.4 degrees
Orbital Period	100 minutes, 28 seconds
Satellite Weight	1,500 pounds (689 kilograms)
Spot Beams	48 per satellite (30 miles in diameter per beam)

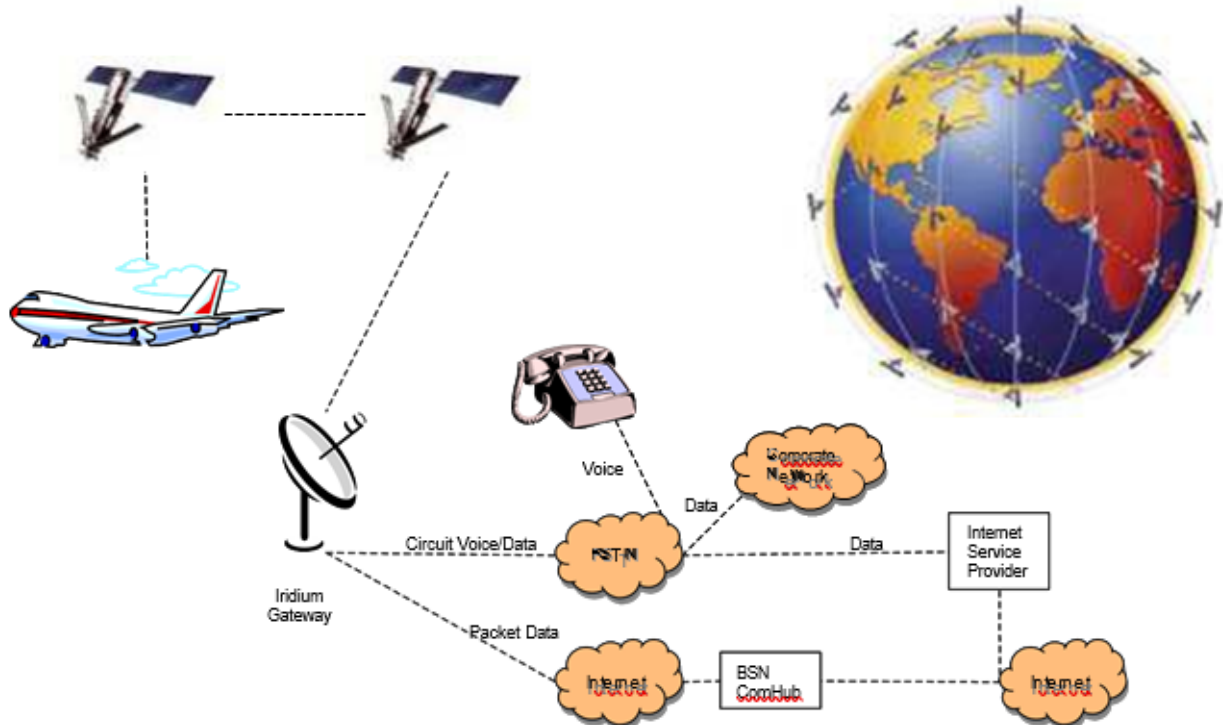

FAA/JAA APPROVAL

Acceptance for the installation and use of the Iridium antenna must be sought through the appropriate offices of the Federal Aviation Administration (FAA), Joint Aviation Authorities (JAA), or other certifying agency.

Installation & Operational Approval Procedures

A functional ground test and an operational flight check procedure should be used to verify proper install, functional performance, and electromagnetic compatibility with existing aircraft systems.

Instructions for Continued Airworthiness

The Iridium antenna requires no routine servicing or maintenance. The installation has no additional overhaul time limitations.

Environmental Qualification

SINGLE-CHANNEL ANTENNA

The single-channel antenna is qualified to DO-160, MIL-C-5541, MIL-E-5400, MIL-STD-810, and TSO-C129.

DUAL-CHANNEL ANTENNA

The dual-channel antenna is qualified to DO-160C, MIL-C-5541, MIL-E-5400, MIL-STD-810 and TSO-C129a.

GNSS & IRIDIUM ANTENNA

The active GPS and Iridium antenna is qualified to FAA TSO-C144, DO-160D, DO-228, MIL-C-5541, MIL-E-5400, MIL-I-45208A, MIL-STD-810, and SAE J1455 standards.

EQUIPMENT SPECIFICATIONS & DRAWINGS

Single-Channel Antenna

The single-channel antenna is a spherical-radius molded radome that provides protection against rain, ice, and lightning strikes. It is qualified for high-speed military and commercial aircraft and is designed to DO-160, MIL-C-5541, MIL-E-5400, MIL-STD-810, and TSO- C129 standards.

Frequency (Iridium/GPS)	1616 -1626.5 MHz / 1575 ±10MHz
VSWR	1.5:1
Polarization	Right Hand Circular Polarization (RHCP)
Impedance	50 ohms
Power Handling	60 watts CW
Gain	+3 dBic @ Zenith
Lightning Protection	DC grounded
Weight	6 oz.
Material	6061-T6 aluminum / thermoset plastic
Finish	Skydrol-resistant enamel

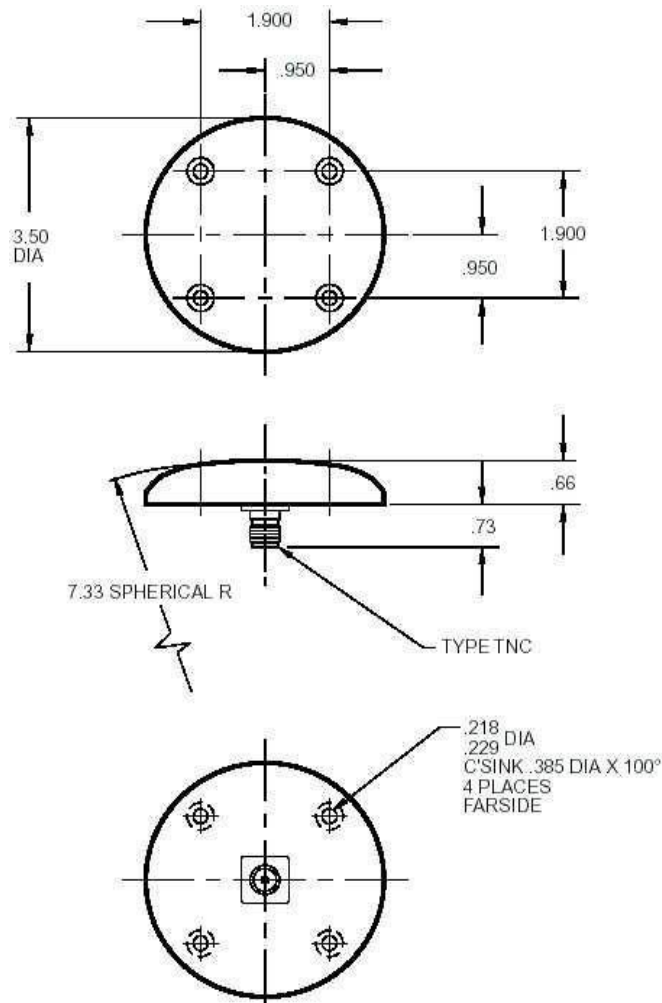

Dual-Channel Antenna

The dual-channel antenna is available for aircraft with multiple Iridium phone installations. The antenna is a low profile dual-element molded radome that provides coverage from 1610 to 1626.5 MHz for excellent Iridium operations and 1530-1660.5 MHz for low gain data application. It is designed to DO-160C, MIL-C-5541, MIL-E- 5400, MIL-STD-810, and TSO-C129a standards and is qualified for high-speed military and commercial aircraft.

Frequency	J1 1610 - 1626.5 MHz J2 1530 - 1660.5 MHz
VSWR	2.0:1
Polarization	Right Hand Circular Polarization (RHCP)
Impedance	50 ohms
Power Handling	60 watts
Gain	+3 dBic @ Zenith
Lightning Protection	DC grounded
Weight	16 oz.
Material	6061-T6 aluminum / thermoset plastic
Finish	Skydrol-resistant enamel

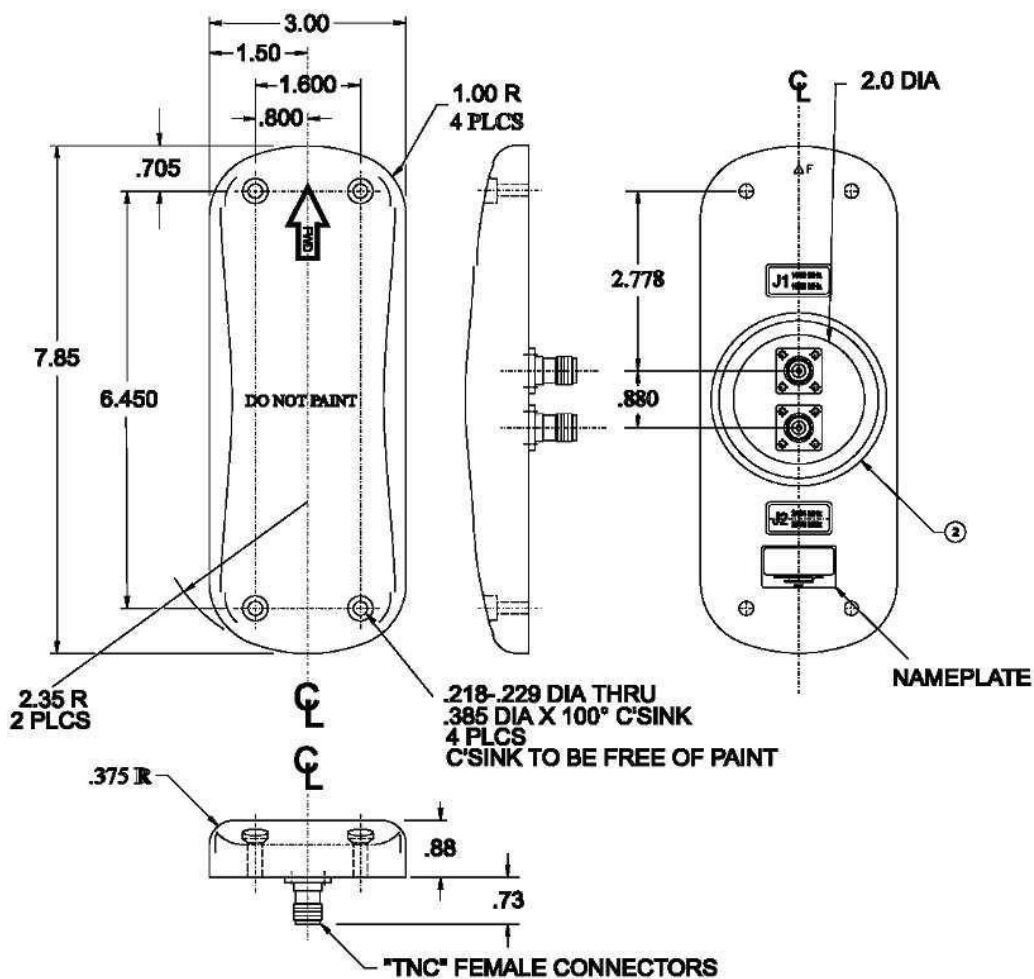

GNSS & Iridium Antenna

The GNSS & Iridium antenna is a rectangular molded radome that provides protection against rain, ice, and lightning strikes. It is qualified for high-speed military and commercial aircraft and is designed to FAA TSO-C144, DO-160D, D0-228, MIL-C- 5541, MIL-E-5400, MIL-I-45208A, MIL-STD-810, and SAE J1455 standards.

ELECTRICAL:	IRIDIUM		OmniSTAR / L-Band L6 Galileo B1 Compass		L1 GPS E1, E2 Galileo L1 IRNSS		L1 GLONASS	
FREQUENCY:	1610.0 - 1626.5 MHz		1542.50 ± 14.0 MHz 1542.50 ± 5.0 MHz 1561.096 ± 10.0 MHz		1575.42 ± 15.0 MHz 1575.42 ± 17.0 MHz 1575.42 ± 12.0 MHz		(1598 - 1606) MHz	
RADIATION PATTERN:								
POLARIZATION:	RHCP		RHCP		RHCP		RHCP	
VSWR:	< 2.0:1		< 2.0:1		< 2.0:1		< 2.0:1	
IMPEDANCE:	50 ohms		50 ohms		50 ohms		50 ohms	
ANTENNA GAIN (dBi):	Free Space	4ft G,P	Free Space	5In G,P	Free Space	5In G,P	Free Space	5In G,P
@ 90 ° (ZENITH):	+ 4,9	+ 5,0	+ 1,9	+ 1,0	+ 4,1	+ 3,2	+ 2,0	+ 2,6
@ 10 ° Elevation:	- 1,0	- 2,5	- 5,0	- 5,7	- 2,8	- 3,2	- 5,1	- 4,2
@ 20 ° Elevation:	+ 1,5	- 0,5	- 3,9	- 3,9	- 1,9	- 1,6	- 4,1	- 2,6
@ 30 ° Elevation:	+ 2,4	+ 1,0	- 2,6	- 3,0	- 0,4	- 0,6	- 2,6	- 1,4
@ 60 - 90 ° Elevation:	> +3,3	> +2,7	> + 0,8	> + 0,2	> 2,9	> + 2,5	> + 0,8	> + 1,8
BEAM WIDTH (3dB):	129 Deg	98-106	95 Deg.	97 Deg.	95 Deg.	100 Deg.	95 Deg.	100 Deg.
AXIAL RATIO:	2 dB	2 dB	1 dB	1 dB	1 dB	1 dB	2 dB	2 dB
LIGHTNING PROTECTION:	DC GROUNDING							
LNA GAIN:	N/A		33 dB		32 dB		31 dB	
LNA NOISE FIGURE:	N/A		3.0 dB		3.0 dB		3.0 dB	
LNA P1dB Out:	N/A		+13 dBm		+13 dBm		+13 dBm	
LNA DC POWER:	N/A		2,5V/20mA, 3V/29mA, 3,3V/35mA, (2,5-24)V/1-50mA					
POWER HANDLING:	1 Watt CW, Optional: 10 Watts 1 Microsec Pulse (-AL-)							

MECHANICAL:

SIZE:	WIDTH: 2.20 In. [55.88 mm], LENGTH: 5.026 In [127.66 mm], HEIGHT: 0,843 in. [21,41 mm]
WEIGHT:	8.0 oz. (226 g)
FINISH:	SKYDROL RESISTANT POLYURETHANE ENAMEL BASE IRIDITE PER MIL-C-5441
MATERIAL:	6061-T6 ALUMINUM ALLOY BASE COMPOSITE RADOME, IMPACT, ABRASION, UV, SOLVENT, AND SKYDROL RESISTANCE, FIRE RETARDANT
CONNECTOR:	GPS: TNC FEMALE, IRIDIUM: N FEMALE (OPTION: SMA, TNC, TNC Bulkhead, N, N Bulkhead, MCX, MMCX, or Cable)

ENVIRONMENTAL:

TEMPERATURE:	-67 °F TO +185 °F [-55 °C TO +85 °C]
ALTITUDE:	70,000 ft.
VIBRATION:	> 30 G's
LEAKAGE:	HERMETICALLY SEALED

FEDERAL & MILITARY SPECIFICATIONS:

DESIGN TO:	FAA TSO-C144, DO-160D, D0-228, MIL-C-5541, MIL-E-5400, MIL-I-45208A, MIL-STD-810, AND SAE J1455
------------	--

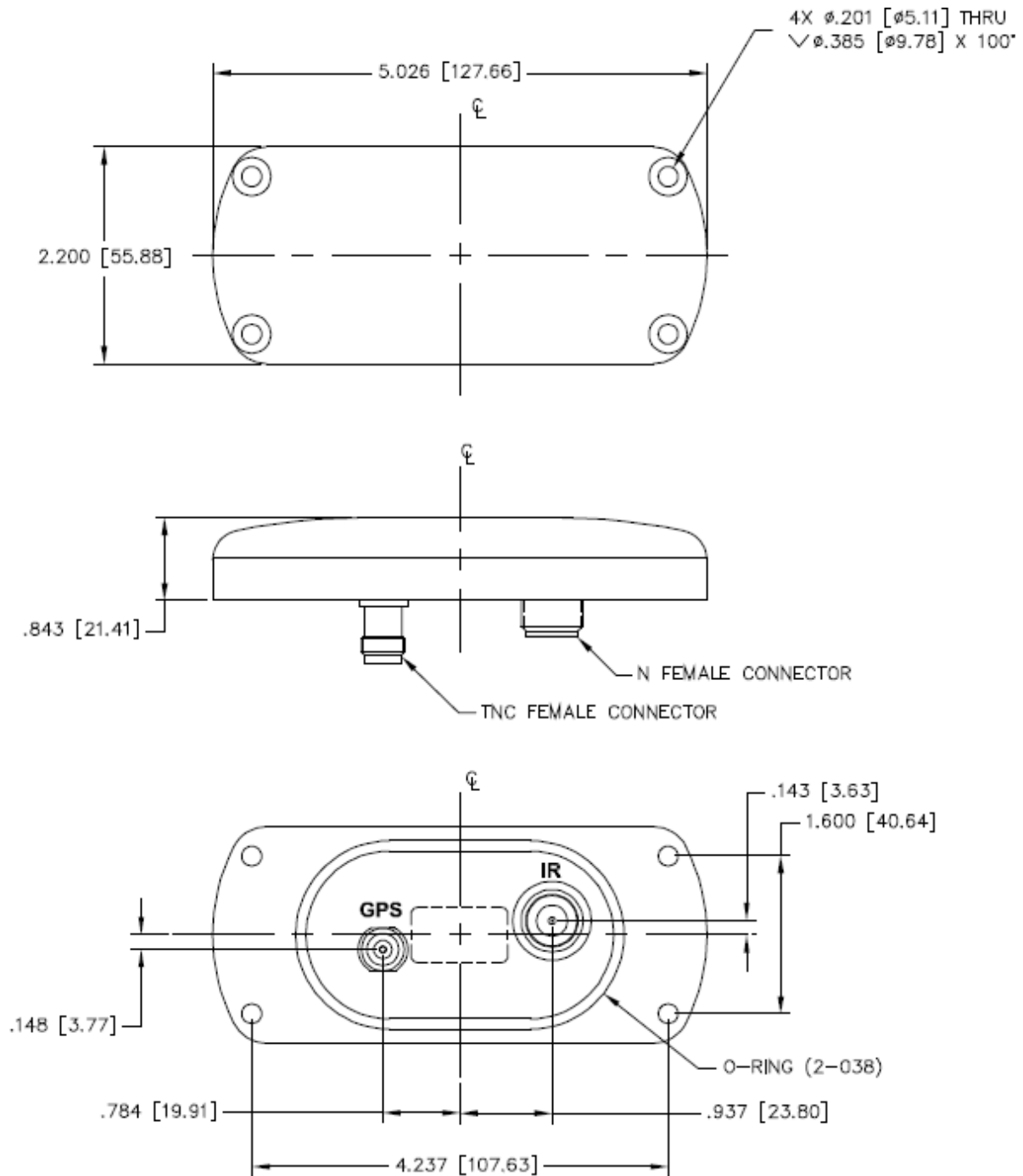

INSTALLATION & WIRING

Generally, aircraft modification consists of installing the Iridium antenna in the aircraft. **NOTE: THE IRIIDIUM ANTENNA REQUIRES PROFESSIONAL INSTALLATION.**

License Requirements

The Iridium phone system has no licensing requirements.

Equipment Required, But Not Supplied

- 1) Mounting Hardware
- 2) Doubler Plate (Dual-Channel only)

Antenna & Antenna Cable Installation

For optimum performance, the antenna must be installed on the upper surface of the aircraft fuselage, away from the vertical stabilizer, and with an unrestricted view of the sky down to eight degrees above the horizon (similar to a GPS antenna).

Transmission from the antenna may be affected by, and can affect, the operation of other systems. It is the installer's responsibility to evaluate the location for any possible RF interference. In particular, the Iridium frequency is near the allocated GPS and Inmarsat band. The antenna should be at least 39 inches (1 meter) from TCAS and Transponder antennas and any L-band antennas, particularly GPS.

Observe all appropriate sections of AC 43.13-1B and AC 43.13-2A.

Strict maximum attenuation requirements for the coax cable and connectors that link the antenna to the Iridium phone must be observed. The signal loss budget, including the antenna cable and all connectors, from the antenna to the Iridium phone is < 2dB at 1626 MHz. The BSN installation kits include the FAA-approved low loss coax antenna cable sized to meet this requirement.

SINGLE-CHANNEL ANTENNA (S67-1575-109) INSTALLATION

This antenna has a low profile, providing structurally insignificant drag loads. The antenna is usually installed using four MS27039C1-10 attachment screws (10-32). However, each aircraft has unique airframe issues. *The installer is responsible for the decision on any antenna installation issue.*

A 1.25-inch (32 mm) diameter penetration, drilled at installation, permits the antenna coax connector to be fed into the aircraft. A doubler, provided with the antenna, reinforces the 1.25-inch diameter penetration. The doubler is 0.040 inch (1.0 mm) thick 6061-T6 aluminum alloy and creates an effective ring of 4.09 inches (104 mm). The doubler is attached to the skin using 16 NAS1097AD3 rivets. *This doubler may NOT be appropriate for your aircraft. The installation material required may vary from aircraft to aircraft and is the responsibility of the installer to determine.*

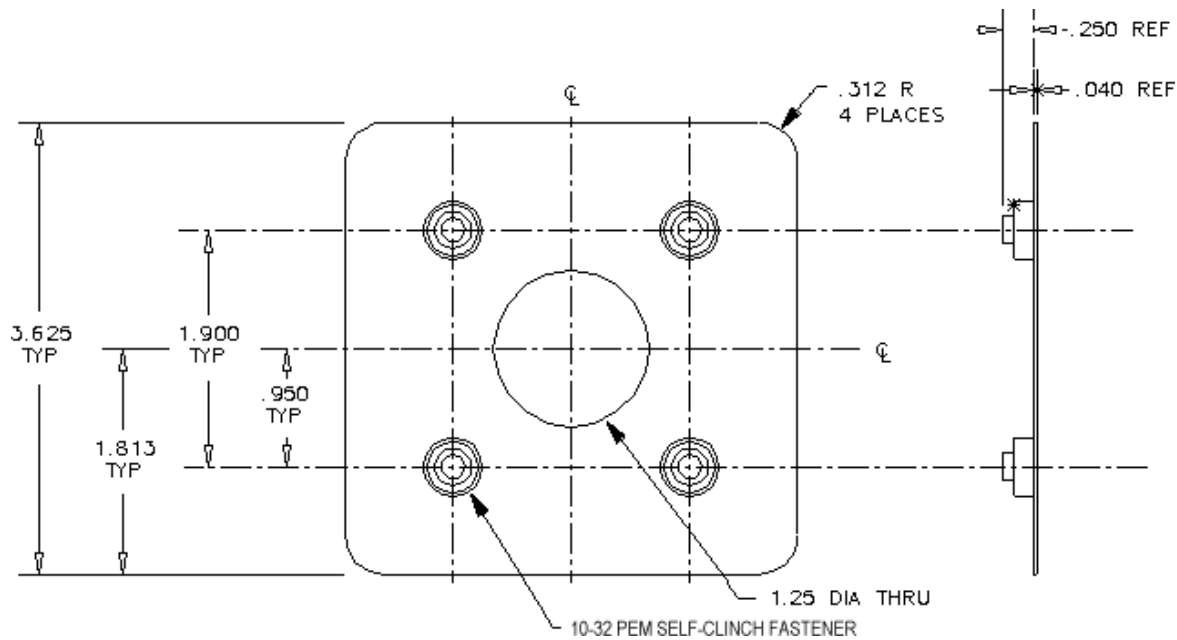

DUAL-CHANNEL ANTENNA (CI 490-501) INSTALLATION

This antenna has a low profile, providing structurally insignificant drag loads. The antenna is usually installed using four MS27039C1-10 attachment screws (10-32). However, each aircraft has unique airframe issues. *The installer is responsible for the decision on any antenna installation issue.*

A 1.25- inch (32 mm) diameter penetration, drilled at installation, permits the antenna coax connector to be fed into the aircraft. No doubler plate is included with the dual-channel antenna since each aircraft has a different shape and design.

GNSS & IRIDIUM ANTENNA (S5GIRG3RR-AP-XTS-1) INSTALLATION

The GNSS & Iridium antenna has a low profile, providing structurally insignificant drag loads. The antenna is usually installed using four MS27039C1-10 attachment screws (10-32). However, each aircraft has unique airframe issues. *The installer is responsible for the decision on any antenna installation issue.*

ANTENNA CABLE INSTALLATION

The antenna cable must be routed from the antenna to Iridium phone.

Strict maximum attenuation requirements for the coax cable and connectors that link the antenna to the Iridium phone must be observed. The signal loss budget, including the antenna cable and all connectors, from the antenna to the Iridium device is < 2dB at 1626 MHz. Maximum cable length is determined by this specification. Measured Voltage Standing Wave Ratio, or VSWR, of the coax cable assembly, antenna, and any bulkhead feed-through adapter must be < 1.5 to 1.

Note: The BSN installation kits include a 15-foot (4.6 m), FAA-approved low loss coax antenna cable sized to meet this requirement. In addition, Blue Sky Network has custom cables lengths and configurations up to 60 feet (18 meters) long to meet your installation requirements. You can also request that one or both end connectors be shipped uninstalled to ease cable routing.

ANTENNA CABLE ROUTING CONSIDERATIONS

- 1) Cable length and routing must be carefully planned before starting the installation.
- 2) Avoid sharp bends in the cable. Exceeding the minimum bend radius of the antenna coax cable may result in permanent degradation of the cable loss.
- 3) Do not locate the cable near aircraft controls.
- 4) Observe all appropriate sections of FAR Parts 23, 25, 27, and 29, as well as AC 43.13-1B and AC 43.13-2A.
- 5) To ensure optimum performance, the antenna cable should be kept a minimum of three feet from high-noise sources and not routed with cables from high power sources.

POST-INSTALLATION PROCEDURES

Ground Test & Operational Flight Check Procedure

A functional ground test and an operational flight check procedure should be used to verify proper installation and functional performance.

The required logbook entries and FAA approvals are the responsibility of the installer. Blue Sky Network assumes no responsibility for either obligation.

Maintenance

AIRCRAFT ANNUAL INSPECTION CONSIDERATIONS

During the aircraft annual inspection:

- 1) Visually inspect the antenna installation for loose fasteners or corrosion.
- 2) Perform a functional system check by making a telephone call.

TECHNICAL SUPPORT

Blue Sky Network is committed to providing the highest level of service and support. If you have any questions or concerns, please feel free to contact us by email or phone; contact information is available at the bottom of this page. For self-help, please visit <https://support.blueskynetwork.com/>.

Thank you for choosing Blue Sky Network!



Blue Sky Network, 5353 Mission Center Rd, Suite 222, San Diego, CA 92108

Phone: +1 858-551-3894

Email: support@blueskynetwork.com | Website: www.blueskynetwork.com